

HeartFelt® Multipanel felt Ceiling System

PRODUCT CHARACTERISTICS:

- Modular linear felt ceiling system
- Panel dimensions **Boxshaped:**
30 x 60 mm, 80 x 35 mm, 130 x 35 mm
180 x 35 mm
- Panels are available in 5 shades of grey
- Panel length 30HL60 : 1000 - 6000 mm
Panel length 80HL35 : 1000 - 4000 mm
Panel length 130HL35 : 1000 - 4000 mm
Panel length 180HL35 : 1000 - 4000 mm
- One standard carrier for all panels

www.hunterdouglasarchitectural.eu

© Registered trademark - a HunterDouglas® product

Project : 3D visualisation, The Netherlands
Product : HeartFelt® Multi-Panel

HunterDouglas 
Architectural

SYSTEM OVERVIEW

- 1 = HeartFelt® Multipanel 30HL60
- 2 = HeartFelt® Multipanel 80HL35
- 3 = HeartFelt® Multipanel 130HL35
- 4 = HeartFelt® Multipanel 180HL35
- 5 = Panel splice (available for all panels)
- 6 = Endcap 30HL60 panel
- 7 = Endcap 80HL35 panel
- 8 = Endcap 130HL35 panel
- 9 = Endcap 180HL35 panel
- 10 = Carrier
- 11 = Carrier splice
- 12 = Quick hanger
- 13 = Stabilisation bracket
- 14 = Stabilisation profile

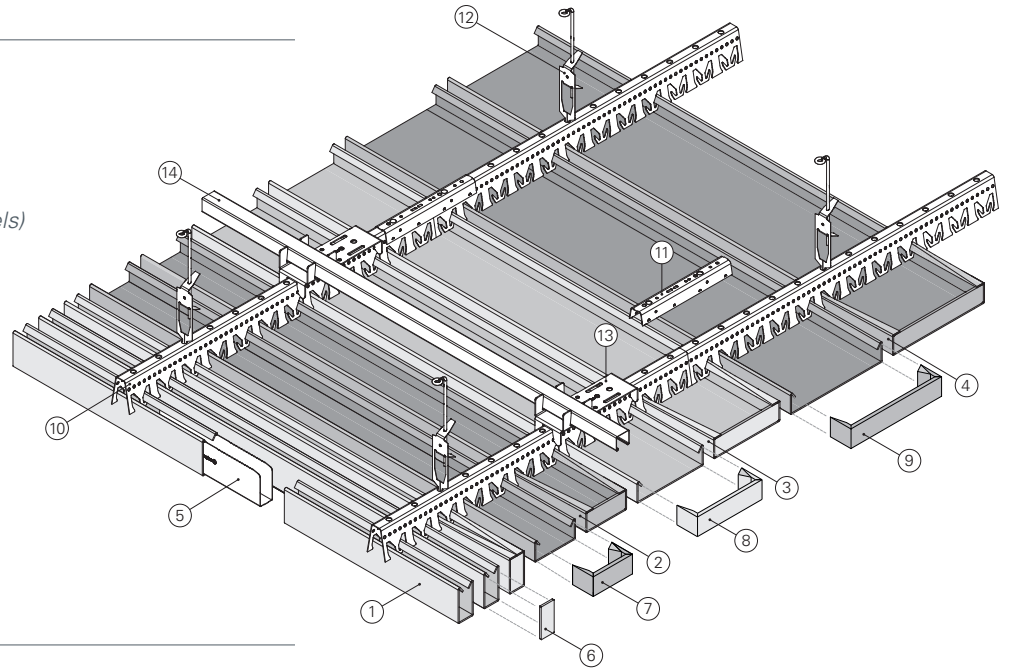

PROFILE

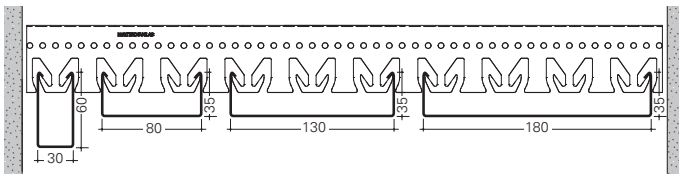

MAXIMUM SPAN

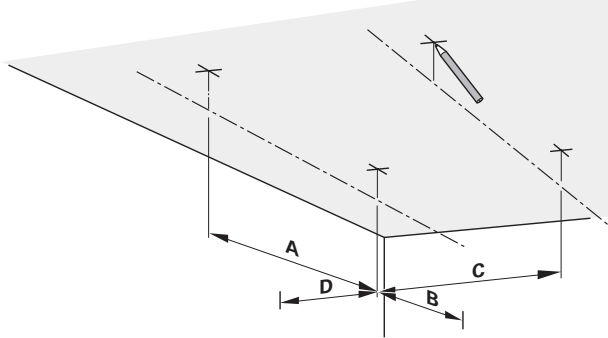

HeartFelt® Multipanel	Maximum Carrier span		Maximum Panel span	
	A	B	C	D
30/80/130/180	1500	300	1200	150

MATERIAL PROPERTIES

- **Material:** non-woven, thermo formable PES-fibers
- **Fire retardant:** class B-s1,d0 EN 13501-1
- **Weight:** Panel 30HL60: 2.9 kg/m² (M50)
 Panel 80HL35: 1.7 kg/m² (M100)
 Panel 130HL35: 1.5 kg/m² (M150)
 Panel 180HL35: 1.4 kg/m² (M200)
- **Light reflection:** depending on colour
- **Exposure class:** A and B EN 13964

CERTIFICATIONS

- Indoor Air Comfort Gold
- French VOC-regulation class A+
- Cradle to Cradle™ Level Bronze
- Oeko-tex Standard 100 klasse IV
- SundaHus Miljødata klasse A
- GreenGuard Gold

Cradle to Cradle Certified™ is a certification mark licensed by the Cradle to Cradle Products Innovation Institute.



ACOUSTICS - α_w

Panel 30HL60

Module (mm)	Joint (mm)	Openness %	α_w
M50	20	40%	0.60 (H)

Panel 80HL35

Module (mm)	Joint (mm)	Openness %	α_w
M100	20	20%	0.65 (H)

Panel 130HL35

Module (mm)	Joint (mm)	Openness %	α_w
M150	20	15%	0.70 (H)

Panel 180HL35

Module (mm)	Joint (mm)	Openness %	α_w
M200	20	10%	0.70 (H)

HunterDouglas Architectural

Hunter Douglas Architectural

Piekstraat 2
 P.O. Box 5072 - 3008 AB Rotterdam - The Netherlands
 Tel. +31 (0)10 - 486 99 11 - Fax +31 (0)10 - 484 79 10
www.hunterdouglasarchitectural.eu